

Data Sheet: LWZ 180/280



- › LWZ 180
- › LWZ 280



- › Centralised ventilation for optimum air quality
- › Heat recovery up to 94%
- › Made in Germany
- › Inbuilt display allows control of the appliance directly from the unit
- › Significantly reduced ventilation noise levels
- › Helps prevent condensation and mould through improved ventilation
- › Air flow rates 60 - 350 m³/h
- › Easy filter change
- › Summer bypass function
- › ERV (Energy Recovery Ventilation) core available for latent energy and humidity management
- › Optional FEB remote control



LWZ 180/280

PREMIUM CENTRALISED VENTILATION WITH HEAT RECOVERY

Both the LWZ 180 and LWZ 280 heat recovery ventilation units are highly efficient appliances, offering heat recovery levels of up to 94% through an optimised cross-flow heat exchanger. This makes the LWZ 180 and LWZ 280 ventilation units an excellent choice for apartments, houses and small commercial properties.

Model	PREMIUM	
	LWZ 180	LWZ 280
	232361	232362
Heat recovery	Up to 94%	Up to 94%
Air flow rate	m ³ /h 60 - 250	60 - 350
Connection	230 V 1/N/PE 50 Hz	230 V 1/N/PE 50 Hz
Current consumption	A 0.6	0.8
Current consumption with preheating coil	A 7.1	7.3
Power consumption	W 74	134
Power consumption with preheating coil	W 1574	1634
IP rating	IP 21	IP 21
Filter class	Coarse G4, M5 (F7 Optional)	
Application range	°C 15 - 35	15 - 35
Max. ambient temperature	°C 40	40
Available external pressure, ventilation	Pa 160	160
Sound power level with standard ventilation and 50 Pa external	dB(A) 43	48
Type of installation	Wall mounted	Wall mounted
Air duct connection	mm 160	160
Condensate connection	mm 22	22
Width	mm 690	690
Height	mm 997	997
Depth	mm 534	534
Weight	kg 78	78
Electrical installation	AS/NZS3000 & local requirements	
Colour	White	White



LWZ 280



Dimensions

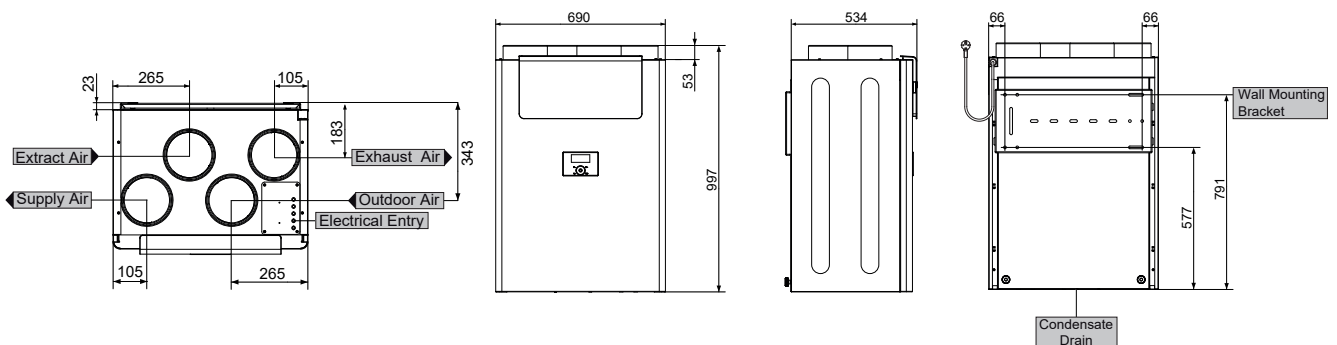

STIEBEL ELTRON is committed to our policy of continual improvement, some features may have subsequently been changed or even removed. Our advisors will be happy to consult with you regarding the currently applicable equipment features. The images used in this data sheet are for reference only.